



**Hornady**  
Accurate. Deadly. Dependable.

## INSTRUCTIONS

# LOCK-N-LOAD® CONCENTRICITY TOOL

Item No. 050076

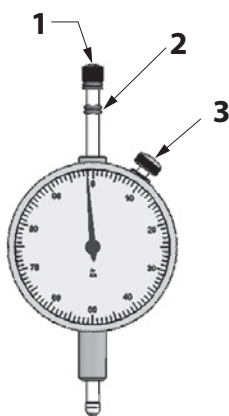

1	DIAL INDICATOR SPINDLE
2	O-RING HOLDS
3	DIAL INDICATOR FACE LOCK
4	DIAL INDICATOR
5	BULLET SPINDLE
6	BULLET SPINDLE SPRING
7	BULLET SPINDLE COLLAR
8	BALL KNOB
9	DIAL INDICATOR LOCK SCREW
10	NYLON-TIPPED THUMB SCREW
11	CRADLE LOCK
12	FRAME
13	INDICATOR/STRAIGHTENING CRADLE
14	CASE HEAD SPINDLE LOCK
15	CASE HEAD SPINDLE

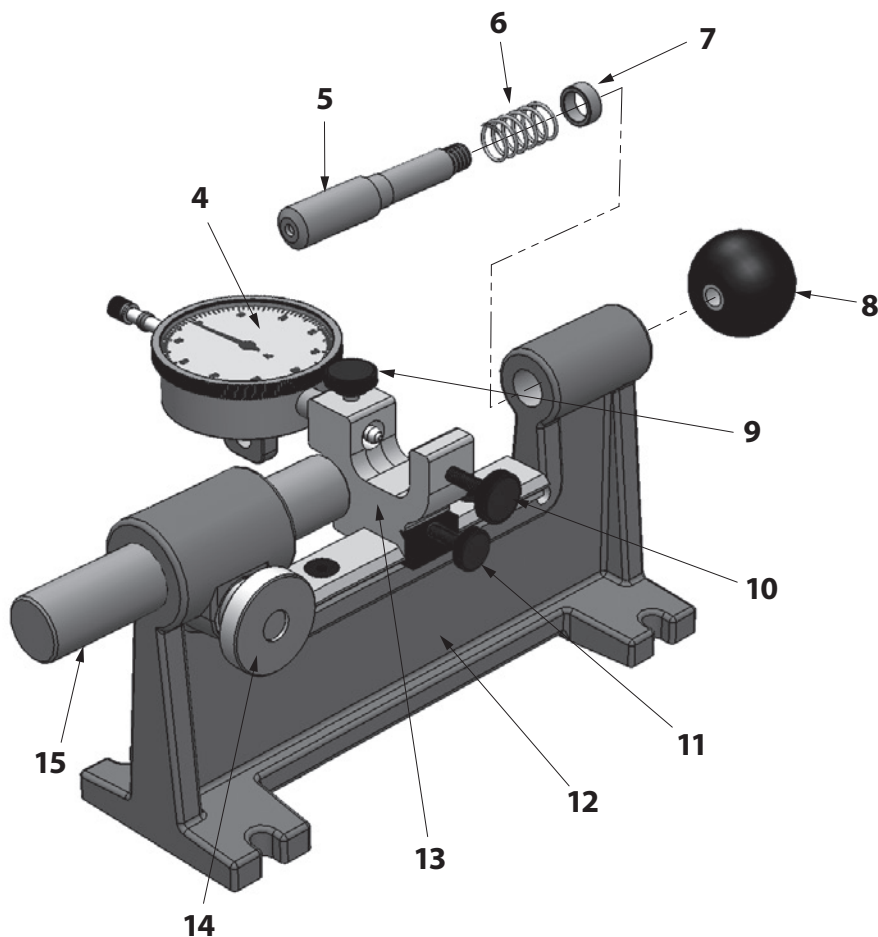

## SETUP

The Hornady® Lock-N-Load® Concentricity Tool ships pre-assembled with a bullet spindle (5) that will work for most applications. However, if a smaller or larger spindle (included) is required, simply unscrew the ball knob (8), remove the bullet spindle (5), bullet spindle spring (6) and bullet spindle collar (7), then place the spring and collar on the spindle of your choice and reassemble in the frame.

Place the dial indicator (4) in the dial indicator hole located on the indicator/straightening cradle (13). Secure the dial indicator by tightening the dial indicator lock screw (9) to hold the dial indicator (4) in position.

Pull the dial indicator spindle (1) back and slide the o-ring holds (2) down to hold the dial indicator spindle (1) from protruding too far into the indicator cradle opening. Also, back the nylon-tipped thumbscrew (10) out of the indicator cradle opening. This will allow the first cartridge to be easily inserted into the Hornady® Lock-N-Load® Concentricity Tool.

Loosen the case head spindle lock (14) and slide the case head spindle (15) rearward.

Place selected cartridge case head in the case head spindle (15) and slide the spindle forward guiding the bullet into the recess in the bullet spindle (5). Continue to push the cartridge forward until the ball knob (8) moves

approximately 1/8 inch away from the frame (12) (this 1/8 inch is a place to start and may be increased or decreased to the user's preference). Now, lock the case head spindle (15) in place by tightening the case head spindle lock (14).

Cartridges can now be removed and replaced by pulling the ball knob (8) away from the tip of the cartridge which will create clearance between the bullet spindle (5) and tip of the cartridge.

Slide the o-ring holds (2) on the dial indicator spindle (1) back to allow spindle to come into contact with the bullet.

Loosen the indicator/straightening cradle (13) by loosening the cradle lock (11), then slide the cradle until the indicator is located where the ogive meets the shank of the bullet. (This position can be adjusted according to bullet design and/or user preference). Now tighten the indicator/straightening cradle (13) with the cradle lock (11).

Adjust the o-ring holds (2) on the dial indicator spindle (1) so that the spindle only drops .020" to .030" when the cartridge is removed from the concentricity tool. This allows the cartridge to be removed and replaced easily.

## OPERATION

At this point you are ready to start inspecting and, if needed, correcting cartridge concentricity.

Place a cartridge in the tool and rotate to indicate run-out.

Note: If the bullet spindle (5) rotates with cartridge, hold ball knob (8) to keep it from rotating, as the cartridge MUST rotate between stationary centers to deliver an accurate measurement.

Set the dial indicator (4) to zero at the cartridges lowest setting by loosening the dial indicator face lock (3) on the side of indicator and rotating the face, or by loosening the dial indicator lock screw (9) and adjusting the indicator in or out.

## STRAIGHTENING CARTRIDGES

With the cartridge at its lowest point on the dial indicator (4), bring the nylon-tipped thumbscrew (10) into contact with the bullet applying pressure. Watch the indicator and take past the cartridge's high point on the dial indicator (4) and then release the nylon-tipped thumbscrew (10). Re-measure concentricity and repeat the process if necessary. The amount of force required to correct the cartridge is determined by multiple factors.

Best accuracy is generally achieved when cartridge concentricity is no more than .002"-.003".

## WARRANTY

All Hornady® reloading tools and accessories are warranted against material defects and workmanship.

This warranty is void if the product (1) has been damaged by accident or unreasonable use, neglect, improper service or other causes not arising out of defects in material or workmanship; or (2) has been altered or repairs have been made or attempted by other than authorized factory personnel; (3) is used commercially; or (4) has been altered or defaced in any way.

This warranty supersedes all other warranties for Hornady® products either written or oral. No other warranty is expressed or implied.

## PRODUCT REGISTRATION AND SERVICE

You must register your product to obtain Warranty Service. Complete the registration form at [hornady.com/warranties](http://hornady.com/warranties).



## TO RECEIVE WARRANTY SERVICE

To report a warranty claim, call Hornady® at 800-338-3220 to request a return authorization number. Returns will not be accepted without prior return authorization by Hornady.®

## POST-WARRANTY SERVICE INFORMATION

For issues concerning service after the Limited Warranty expires, contact Hornady® at 800-338-3220.

## PRODUCT SERIAL NUMBER AND REFERENCE INFORMATION

You must register your product in order to obtain warranty service. In the event you should need service for your product, please note the following information:

Serial Number \_\_\_\_\_

Date Purchased \_\_\_\_\_

Retailer \_\_\_\_\_

## WARNINGS:

Reloading is an enjoyable and rewarding hobby that is easily conducted with safety. Carelessness or negligence can make any hobby, especially reloading, hazardous. All Hornady® reloading tools and supplies are designed with the user's safety in mind. However, since Hornady® Manufacturing Co. has no control over the manner in which products or components are used in the reloading operation, it cannot assume any liability for damage, which may result from the use of the products or the information given herein. It is the responsibility of you, the user, to follow generally accepted safety practices.

Use all reloading tools and supplies as the manufacturer recommends. Study the instructions carefully and become thoroughly familiar with the operation of those tools and supplies.

Observe good housekeeping in the reloading area. Keep all tools and supplies neat, clean and orderly. Promptly clean up all primer and powder spills.

Know your components. Study manufacturers' manuals to properly identify all components and use them according to their recommendations.

Perform all tasks relative to reloading only when you can give it your complete attention. Do not perform these activities when you are ill, fatigued, or distracted. Develop a routine to avoid mistakes and haste.

Always wear eye protection. You assume reasonable risk during most reloading related tasks and doing so without safety glasses is adding an unnecessary additional risk.

Use only laboratory tested and approved reloading and component data and reloading procedures. We highly recommend the Hornady® "Handbook of Cartridge Reloading" in its most current Edition as your source for the most modern and current information.



**Hornady**  
*Accurate. Deadly. Dependable.*